

## Around the Shop

### Drill Depth Stop

Manufactured stop collars are great for drilling holes at a consistent depth. But they don't help keep the bit square to the board you're drilling into. So I made a simple depth stop in my shop that works for both.

The stop is made from two pieces of wood glued together (right illustration). Then I drill a hole for the size bit needed at the drill press.

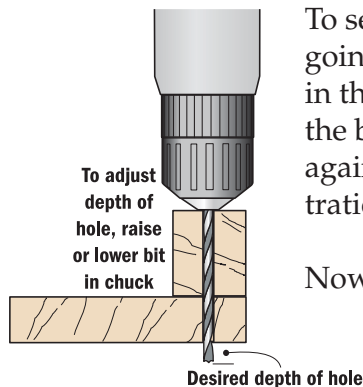

To set the depth of the hole you're going to drill, place the bit loosely in the drill and slide the stop over the bit. With the stop resting against the chuck, set the depth of the bit and tighten it (bottom left illustration).

Now clamp the jig to your workpiece to drill the hole. The stop holds the bit square to the workpiece, as shown.

